

L1356 Rev. A 01/03

Index:

English:	1-4
Français:	N/A
Deutsch:	N/A
Italiano:	N/A
Español:	N/A
Nederlands:	N/A
Portuguese:	N/A
日本語	N/A



Repair Parts Sheets for this product are available from the Enerpac web site at www.enerpac.com, or from your nearest Authorized Enerpac Service Center or Enerpac Sales office.

1.0 IMPORTANT RECEIVING INSTRUCTIONS

Visually inspect all components for shipping damage. Shipping damage is **not** covered by warranty. If shipping damage is found, notify carrier at once. The carrier is responsible for all repair and replacement costs resulting from damage in shipment.

SAFETY FIRST

2.0 SAFETY ISSUES



Read all instructions, warnings and cautions carefully. Follow all safety precautions to avoid personal injury or property damage during system operation. Enerpac cannot be responsible for damage or injury resulting from unsafe product use, lack of maintenance or incorrect product and/or system operation. Contact Enerpac when in doubt as to the safety precautions and operations. If you have never been trained on high-pressure hydraulic safety, consult your distribution or service center for a free Enerpac Hydraulic safety course.

Failure to comply with the following cautions and warnings could cause equipment damage and personal injury.

A **CAUTION** is used to indicate correct operating or maintenance procedures and practices to prevent damage to, or destruction of equipment or other property.

A **WARNING** indicates a potential danger that requires correct procedures or practices to avoid personal injury.

A **DANGER** is only used when your action or lack of action may cause serious injury or even death.



WARNING: Wear proper personal protective gear when operating hydraulic equipment.



WARNING: Stay clear of loads supported by hydraulics. A cylinder, when used as a load lifting device, should never be used as a load holding device. After the load has been raised or lowered, it must always be blocked mechanically.



WARNING: USE ONLY RIGID PIECES TO HOLD LOADS. Carefully select steel or wood blocks that are capable of supporting the load. Never use a hydraulic cylinder as a shim or spacer in any lifting or pressing application.



DANGER: To avoid personal injury keep hands and feet away from cylinder and workpiece during operation.



WARNING: Do not exceed equipment ratings. Never attempt to lift a load weighing more than the capacity of the cylinder. Overloading causes equipment failure and possible personal injury. The cylinders are designed for a max. pressure of 700 bar [10,000 psi]. Do not connect a jack or cylinder to a pump with a higher pressure rating.



Never set the relief valve to a higher pressure than the maximum rated pressure of the pump. Higher settings may result in equipment damage and/or personal injury.



WARNING: The system operating pressure must not exceed the pressure rating of the lowest rated component in the system. Install pressure gauges in the system to monitor operating pressure. It is your window to what is happening in the system.



CAUTION: Avoid damaging hydraulic hose. Avoid sharp bends and kinks when routing hydraulic hoses. Using a bent or kinked hose will cause severe back-pressure. Sharp bends and kinks will internally damage the hose leading to premature hose failure.



Do not drop heavy objects on hose. A sharp impact may cause internal damage to hose wire strands. Applying pressure to a damaged hose may cause it to rupture.



IMPORTANT: Do not lift hydraulic equipment by the hoses or swivel couplers. Use the carrying handle or other means of safe transport.



CAUTION: Keep hydraulic equipment away from flames and heat. Excessive heat will soften packings and seals, resulting in fluid leaks. Heat also weakens hose materials and packings. For optimum performance do not expose equipment to temperatures of 65°C [150°F] or higher. Protect hoses and cylinders from weld spatter.



DANGER: Do not handle pressurized hoses. Escaping oil under pressure can penetrate the skin, causing serious injury. If oil is injected under the skin, see a doctor immediately.



WARNING: Only use hydraulic cylinders in a coupled system. Never use a cylinder with unconnected couplers. If the cylinder becomes extremely overloaded, components can fail catastrophically causing severe personal injury.



WARNING: BE SURE SETUP IS STABLE BEFORE LIFTING LOAD. Cylinders should be placed on a flat surface that can support the load. Where applicable, use a cylinder base for added stability. Do not weld or otherwise modify the cylinder to attach a base or other support.



Avoid situations where loads are not directly centered on the cylinder plunger. Off-center loads produce considerable strain on cylinders and plungers. In addition, the load may slip or fall, causing potentially dangerous results.



Distribute the load evenly across the entire saddle surface. Always use a saddle to protect the plunger.



IMPORTANT: Hydraulic equipment must only be serviced by a qualified hydraulic technician. For repair service, contact the Authorized ENERPAC Service Center in your area. To protect your warranty, use only ENERPAC oil.



WARNING: Immediately replace worn or damaged parts by genuine ENERPAC parts. Standard grade parts will break causing personal injury and property damage. ENERPAC parts are designed to fit properly and withstand high loads.

3.0 SPECIFICATIONS

Model No.	Ratio	Oil Piston Stroke	Per Stroke Oil Output	Oil Pressure at 100PSI Air Pressure	Max Oil Pressure
B-2009	20:1	5.20 in.	9.30 cu. in.	2000 psi	2500 psi
B-3006	30:1	5.20 in.	6.20 cu. in.	3000 psi	3750 psi
B-5003	50:1	5.20 in.	3.70 cu. in.	5000 psi	6250 psi

Note: Shipping box contains fittings for NPT hook-up. The fitting with the tapered male threads goes into the 3/8 BSPT air inlet.

- Ambient Temperature Range.....-4°F (-20°C) to +176°F (80°C)
- Recommended Oil Temperature+59°F (15°C) to +131°F (55°C)
- Minimum Operating Air Pressure40 psi (3 bar)
- Maximum Operating Air Pressure125 psi (9 bar)
- Air Consumption0.95 cu. ft. per stroke
- Reservoir Capacity50 cu. in.
- Usable Oil Capacity13.4 cu. in.
- Maximum Cycle rate10 cycles per minute
- Air Piston Retract Speed (from full extend)
@ 86 psi (6 bar).....Max. 3.2 sec.
- Return Spring Force @ Initial Position.....57 lbs.
- Return Spring Force @ Maximum Compression1041 lbs.
- Stroke Sensing Position Before Full Stroke1.04 in.
- Sensing Contact Capacity30 VDC, 3 amps

4.0 INSTRUCTIONS

4.1 General Description

Air operated hydraulic boosters convert low pressure air to high pressure hydraulic oil for operating hydraulic cylinders, clamps or similar devices. Primary booster components are, the air piston and the hydraulic cylinder plunger. Air pressure, into the booster, exerts a force against the air piston causing it to move forward. The forward motion compresses the piston return spring and moves the hydraulic plunger in the oil cylinder. The plunger compresses the oil in the cylinder developing high pressure at the outlet port.

Pressure intensification is determined by the air piston to hydraulic plunger ratio. If the booster ration is 20:1 100 psi air pressure will produce 2000 psi hydraulic pressure. Air pressure of 80 psi will produce 1,600 psi hydraulic pressure. To determine actual holding forces, multiply the effective area of a working cylinder by the hydraulic pressure being produced. The result is holding force in pounds.

4.2 Selecting Cylinders and Boosters

- Determine the holding force required for the application.
- Determine input air pressure available.
- Determine volume of oil required in the hose or pipe from the booster to the working hydraulic cylinder or clamping devices.

TO FIND: Cylinder Holding Force (lbs) = Cylinder Effective Area (sq. in.) x Hydraulic Working Pressure (psi)



TO FIND: Cylinder Oil Capacity (cu. in.) = Cylinder Effective Area (sq. in.) x Cylinder Stroke (inches)



TO FIND: Total number of Cylinders that can be used with Booster or Pump = Useable Oil Capacity of Pump (or) Booster oil Output (cu. in.) ÷ Oil Capacity of Cylinder (cu. in.)

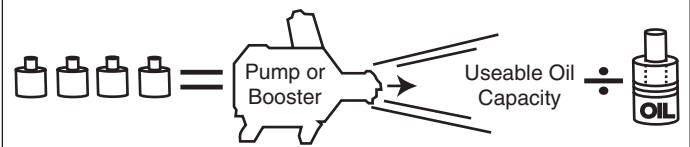

Note: Any cylinder can be matched with any pump or booster as long as the pump or booster has enough useable oil capacity (cubic inches) to transmit and fully extend the cylinder or cylinders.

Your only other consideration is knowing the maximum Hydraulic Pressure Range (psi) of the selected pump or booster for determining the "Cylinder Holding Force" of the cylinder or cylinders.

The selected pump or booster will operate at various desired pressure ranges within its maximum rated capacity. Therefore, the "Workholding Cylinders" will operate at many desired workholding forces by merely regulating the hydraulic operating pressure (psi) of the pumps or boosters.

5.0 INSTALLATION

1. Install the booster in a location which is higher than the working cylinders. The booster can be mounted in the horizontal or one vertical position. When mounting vertically, the hydraulic output end (port) must face up.
2. To mount the booster, remove the capscrew and acorn nuts securing the bracket to the booster.
3. Re-position the booster bracket using any of the six positions around the circumference of the booster. Be sure all capscrews are firmly tightened.
4. Install four mounting screws through the bracket and into the mounting plate (figure 1).

Note: When mounting the booster, the air fill cap and sight gauge should always remain visible and useable to permit checking and re-filling the reservoir.

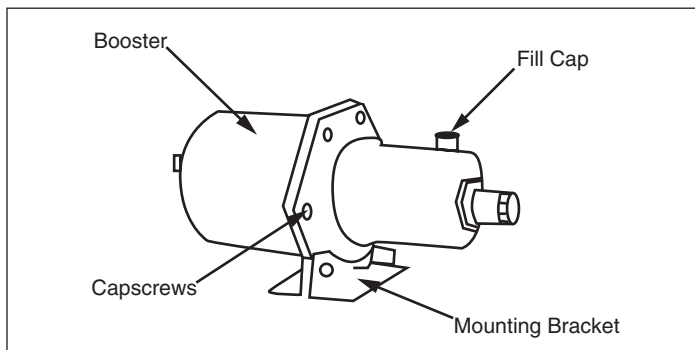

Figure 1

6.0 INCOMING AIR SUPPLY

Compressed air, to the booster, must be clean, dry and lubricated to protect the booster components. If properly treated air is not available, install an Enerpac regulator/filter/lubricator in the air line leading to the booster control valve. The regulator/filter/lubricator provides the following advantages:

1. Removes dirt and moisture from the air
2. Provides a mist of lubrication in the air supply which protects control valves and booster internal parts. Filter lubricators use Enerpac hydraulic oil.
3. Contains an air regulator valve and gauge to adjust air pressure to the booster.

7.0 AIR AND OIL CONNECTIONS



Caution: Teflon tape is an excellent thread sealer, however, if not properly applied small pieces can tear loose and enter the hydraulic system causing restrictions and potential malfunctions. Use 1 1/2 wraps and leave the 2 threads, at the end of fitting, without tape.

1. A 3-way, 2-position directional control valve (VA-42) is required to operate booster. Locate the valve within six feet of the booster, between the regulator/filter/lubricator and the booster inlet port. Valve port sizes are 3/8" - 18 NPT.
2. Connect the air supply line to the input port on the regulator/filter/lubricator (3/8" - 18 NPT).

3. Install an air line from the regulator/filter/lubricator outlet port to the VA-42 valve, port No. 3 (3/8" - 18 NPT).
4. Mount the VA-42 control valve to a solid base. Use the three mounting holes in the valve body.
5. Connect an air line from the VA-42 control valve, port No. 4, to the booster inlet port (figure 2). Valve port No. 1 remains open for exhausting air.

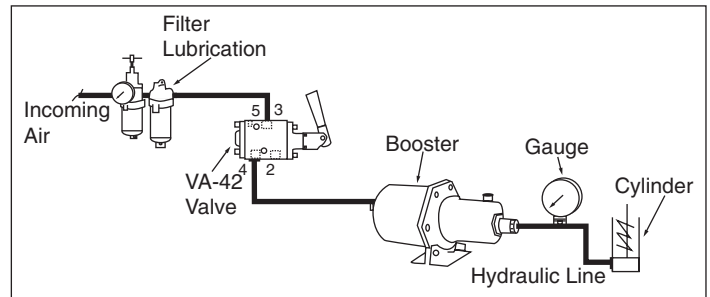

Figure 2

6. Attach a hydraulic line from the booster to the system working components (ie. cylinder, clamps or valves). Fill booster hydraulic reservoir with ENERPAC oil, approximately 1.75 quart.

8.0 BOOSTER OPERATION

Booster operating speed depends on factors including working cylinder strokes, valving, hose lengths and port sizes.

1. Keep hose or pipe lengths reasonably short.
2. Provide clean, dry, lubricated air supply at 40 psi minimum to 125 psi maximum.
3. All hoses, fittings, piping and associated components must be pressure rated to withstand maximum system pressure.
4. Maintain booster oil level in the reservoir. Check sight gauge frequently. Repair leaks immediately.
5. Prior to operation, bleed system to remove air trapped in hydraulic components.
6. Bleeding Hydraulic System
 - (a) Check booster reservoir level. Fill to capacity.
 - (b) Activate booster to complete 2 or 3 cycles and pump oil into entire system.
 - (c) Loosen a fitting (furthest from booster). Cover fitting with rags to prevent oil splatter.
 - (d) Activate booster to full advance, tighten fitting, retract booster.
 - (e) Add hydraulic oil to booster reservoir.
7. **MAGNETIC SENSOR:** The sensor connections are available to connect optional indicator lights or buzzers which actuate upon completion of the hydraulic plunger stroke. Figure 3 illustrates a typical light connection.

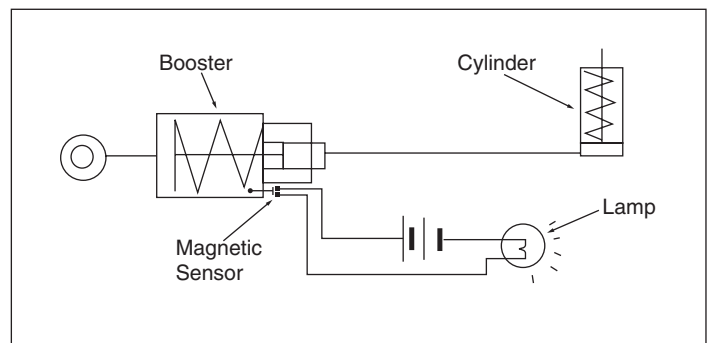

Figure 3

8.1 Operation

1. Position all working components and ensure oil connections are complete.
2. Adjust air supply to provide required booster pressure.
3. Booster is activated by pulling handle on the control valve. When handle is released, the booster retracts via return spring. Working cylinders or clamps also retract unless a shut-off valve has been installed to maintain pressure beyond the booster.

9.0 MAINTENANCE

1. Frequently check booster reservoir sight gauge to ensure oil level remains at proper level. Small red circle, in sight gauge, is maximum level.
2. After system repairs or oil changes, the hydraulics must be bled to remove trapped air.
 - (a) Loosen a fitting furthest from the booster.
 - (b) Activate booster to fully advance the hydraulic plunger. Tighten the fitting.
 - (c) Re-fill booster reservoir. If working system components continue to function erratically or very slow, bleed system, check for leaks, repair or replace faulty items.
3. Changing Hydraulic Oil
 - (a) Change intervals are: every 150 hours during normal operating conditions, every 50 hours under dirty, dusty or extremely humid conditions.
 - (b) Place a drain pan under booster outlet port. Remove hydraulic line. Tip booster to drain oil into the pan.
 - (c) Re-install hydraulic line, Remove red fill cap and re-fill reservoir (1³/₄ quart). When oil appears in sight glass red circle, reservoir is full.