

Pilot ratio: 7:1

Flow: 38 l/min max.

- E** Válvulas antiretorno pilotada
- F** Clapets antiretour piloté
- D** Rückschlagventile

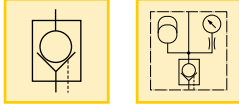

To hold cylinder load and ensure remote unlocking

- Fast check-off response
- Hardened seats ensure long life and positive pressure holding
- Built-in accumulator to maintain system pressure
- Mounting holes
- Manifold mount body MVM-72

Product selection

Pilot ratio	Accumulator included	Maximum oil flow l/min	Maximum pressure bar	Model number	Oil ports	Optional charging tool for ACL	kg
7 : 1	-	38	350	MV-72	G 1/4"	-	1,8
7 : 1	ACL-22	38	350	MV-722B	G 1/4"	WAT-2	2,7
7 : 1	ACL-202	38	350	MV-7202B	G 1/4"	WAT-2	3,4
7 : 1	-	38	350	MVM-72	G 1/4"	-	1,4

For more information on ACL-series Accumulators see page 124.

MV-722B, -7202B

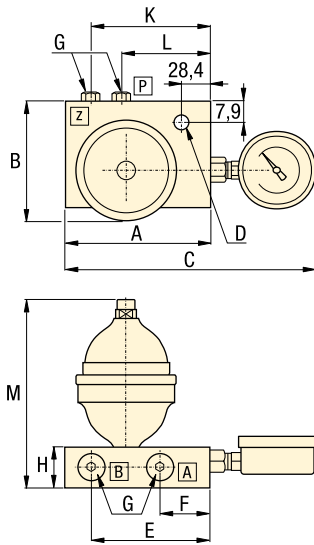

MV-72

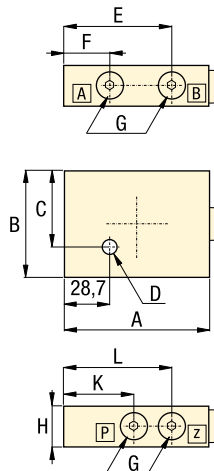

MVM-72

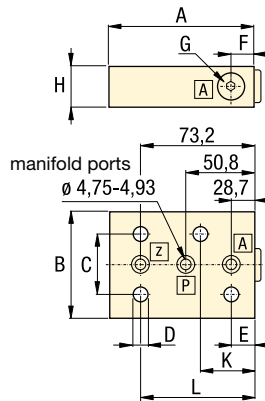

- A** = Cylinder advance
- B** = Cylinder retract
- P** = Pressure
- Z** = Pilot

Product dimensions in mm []

Model number	A	B	C	D	E	F	G	H	K	L	M
MV-72	89,0	63,5	55,6	7,1	73,2	28,7	G1/4"	31,8	50,8	73,2	-
MV-722B	89,0	71,1	184,2	7,1	73,2	28,4	G1/4"	31,8	73,2	50,8	145
MV-7202B	89,0	92,4	181,1	7,1	73,2	28,4	G1/4"	31,8	73,2	50,8	185
MVM-72	89,0	63,5	38,1	7,1	28,7	28,4	G1/4"	31,8	44,5	73,2	-

Seal material: Buna-N.
Manifold O-rings included with MVM-72. For manifold mounting installation information consult Enerpac for surface preparation.

www.enerpacwh.com

Shown: MV-72



MV-series

Pilot operated check valves check the oil flow with a built-in pilot circuit providing fast, automatic check-off for your workholding applications.

The pilot operated check valves with built-in accumulator help to maintain system pressure due to minor oil loss.

Application

Added capability to open with pilot pressure to allow cylinders to retract. By using a pilot operated check valve, cylinder retraction can be accomplished automatically without operator activity.

Options

Fittings

194 ▶

